



SOFT QUIET RIDE | STRONG | DURABLE | AWESOME ON WATER PERFORMANCE |

2008 Catalogue



P4 – 3.00 Tuff Tender



P6 – 4.10 Challenger



P8 – 4.50 Drifter | **New**



P10 – 4.80 Brumby | **New**



P12 – 5.30 Warrior



P14 – 5.99 Frontier

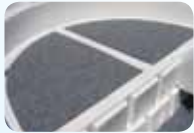

P16 – Accessories



P17 – Trailers



P18 – How Tough are Polycrafts



P19 – Testimonials

Polycraft Boats - a new era

The emergence of roto-moulded polyethylene boats is one of the fastest growing trends in the marine industry today. Canoes, sailing boats and now outboard powered fishing and recreational boats are taking advantage of this unique material which provides customer benefits well in excess of alternative materials traditionally used in the industry.

Polycraft are dedicated to producing strong, low maintenance boats perfect for the hard core fisherman and the recreational boater.



Polycraft is a division of **National Poly Industries** which since 1997 has manufactured and supplied a range of Roto-moulded polyethylene products including rainwater tanks, agricultural products and aquaculture equipment.

Strength, stability and a soft, quiet ride coupled with awesome on water performance.

When you combine all the benefits found in our range of Polycraft boats, it's easy to understand why they are the smart choice for fishing, recreational and commercial use.



The environmental impact of Polyethylene

Polyethylene is one of the most environmentally friendly materials used in the manufacture of marine products.

The polyethylene used in the manufacture of Polycraft boats is sourced from Australian natural gas, processed in Sydney and compounded in Brisbane to include colour, UV inhibitors and other additives.

Polyethylene is not classified as hazardous according to the criteria of the National Occupational Health and Safety Committee and the poly pellets used in the manufacturing process are considered to be environmentally inert.

During the manufacturing process Polyethylene has minimal concentration of major fume constituents, which means that there is minimal discharge into the atmosphere.

There is no waste in the manufacturing process as all off cuts are returned to the compounder for recycling and then reused in the manufacture of a wide range of products including road barriers, pallets etc.

Polyethylene provides a clean, recyclable alternative to traditional boat building materials.

Truly the material of the 21st Century.



The unique hull design features pronounced reverse chines which contribute to unmatched stability at rest. The reverse chines also promote lift when accelerating onto the plane and allow for tighter cornering at high speed.



Polycraft boats feature a unique, soft ride. Polycraft boats flex to absorb the impact of the sea, just like the shock absorbers on your car absorb and deflect the jarring from potholes in the road.



Polycraft's dual wall hull absorbs both engine noise and the noise of the sea. This result is a quieter ride and a more enjoyable day on the water. If fishing is your passion you may benefit from quietly approaching your favourite fishing spot.



Polyethylene has natural buoyancy and will float unaided when placed in water. The unique dual wall construction traps air in the cavity between the dual walls and helps contribute to buoyancy.



Polyethylene has been shown in independent tests to have five times the impact resistance of fibreglass. This makes Polycraft one of the strongest boats on the market providing trouble free boating for many years.



Polyethylene is very easy to maintain, clean and repair. In addition, it is less susceptible to marine growth than many other materials.



Polyethylene is an inert material that is not affected by electrolysis that may be found in aluminium boats or osmosis that can affect fibreglass boats. In the harsh marine environment a Polycraft will keep looking good for longer.



Polycraft boats are manufactured from UV stabilised marine grade polyethylene designed for extended use in direct sunlight. The colour is part of the material so your boat should retain the original colour and will never need painting.



The unique dual wall hull is manufactured in one piece. There are no seams, welds or joins so the hull is extremely strong and durable.



If used for recreational purposes, Polycraft offers a four year manufacturer's warranty. A one year warranty applies for commercial use (see warranty statement for full terms and conditions).

3.00 Tuff Tender

The 3.00 Tuff Tender, incredibly stable for a ten footer. Great for use as a tender or car topper.



The 3.00 Tuff Tender was originally designed for use as a tender for larger craft and is a popular choice in this category as Polyethylene is not abrasive against gel coated and painted surfaces.

However, due to its awesome stability and safety attributes born from its dual skin and tri hull design, it has become an increasingly accepted option as a small fishing boat for protected waterways and freshwater impoundments.

The recessed stainless steel handles make it easy for two people to carry, while also providing lifting points for davits.

The moulded anchor well, cleat and stainless steel shackle ensure easy towing, anchoring and mooring.

Available in eight great classic Polycraft colours.

Specifications

Length:	3.00m
Length (boat/motor/trailer):	4.30m
Height on trailer:	1.05m
Beam:	1.40m
Depth:	0.54m
Weight:	80kg
Shaft length:	15 inches
HP rating:	15HP
Capacity:	3 people (225kg)



Standard Features

- Anchor well
- Bow shackle
- Cleat
- Polycraft logo
- Rod holders (x2)
- Rowlocks
- Stainless steel handrails (x4)
- Transom plate

Optional Features

- Carpeted floor
- Survey standard foaming



White

Yellow

Apple Green

Teal

Cobalt Blue

Regal Blue

Torris Blue

Barrier Red

Available Colours

4.10 Challenger

V-nose punt design with a large front and rear casting deck. If you are a keen angler or enjoy just getting out and exploring the rivers and bays, the 4.10 Challenger is the boat for you.



The 4.10 Challenger is a classic V-nose punt design. The pronounced reverse chines provide a degree of stability at rest that is unmatched by many other boats in this class.

The 4.10 Challenger features a full floor, front and rear casting decks and generous under floor storage to help keep the boat tidy and clutter free.

The 4.10 Challenger's twin front 110 litre storage bins can be used as an ice box or storage for all the gear you need for a great day on the water. They can also be converted to use as live wells for competition style fishing.

Available in Open, Centre Console and Side Console models, and in eight great classic Polycraft colours.

The soft, quiet ride of the 4.10 Challenger distinguishes it from many other boats in its size class. The reason for the great ride lies in the Polyethylene hull, which absorbs on water vibration and noise into the hull and not the occupants.

Standard Features

- Anchor well
- Bow and hand rails
- Casting platform
- Pinstripes and Polycraft logo
- Rod holders (x2)
- Split front hatch storage
- Winch point

Centre Console (only)

- Centre console box and hand rail
- Non-feedback steering

Side Console (only)

- Driver's pedestal box and seat
- Non-feedback steering
- Side console box and screen

Optional Features

- Carpeted floor
- Carpeted front and rear casting decks
- Passenger pedestal box and seat
- Rear storage/bait box
- Side pockets
- Shelf (centre console only)
- Survey standard foaming



Specifications

Length:	4.10m
Length (boat/motor/trailer):	5.20m
Height on trailer:	2.00m
Beam:	1.85m
Depth:	0.75m
Weight (inc. floors):	
Open Boat	280kg
Side Console	295kg
Centre Console	305kg
Shaft length:	20 inches
HP rating:	
Open Boat	40HP
Centre Console	50HP
Side Console	50HP
Capacity:	4 people (300kg)

Side Console



Centre Console



Open Boat



White

Yellow

Apple Green

Teal

Cobalt Blue

Regal Blue

Torris Blue

Barrier Red

Available Colours

4.50 Drifter

Set to become Polycraft's most popular model because of its all-round capabilities both inshore and offshore.

New Release



The new 4.50 Drifter is set to become the most popular boat in the Polycraft range because of its all-round capabilities both inshore and offshore.

Available in Frontrunner, Centre Console, Side Console and Open models, this is the boat that will make every day on the water a day to remember.

Whether you are out fishing or just enjoying a relaxing day on the water with family and friends there is a 4.50 Drifter model that will meet your needs.

The 4.50 Drifter offers the stability normally associated with much larger boats, while at the same time retaining the benefits of being easy to tow and maintain.

With generous storage under the split front hatch, as well as in the two huge rear storage bins, this boat is built for the fisherman and boater who likes to keep a tidy deck.

Available in eight great, classic Polycraft colours.

Standard Features

- Anchor well
- Bow and hand rails
- Bow roller
- Front casting deck
- Pinstripes and Polycraft logo
- Rod holders (x2)
- Winch point

Frontrunner (only)

- Console and screen (x2)
- Pedestal box and seat (x2)
- Non-feedback steering

Centre Console (only)

- Centre console box, screen and hand rail
- Non-feedback steering

Side Console (only)

- Side console and screen
- Non-feedback steering

Optional Features

- Carpeted floor
- Rear casting deck insert
- Side pockets
- Ski hooks
- Survey standard foaming
- 70 litre underfloor fuel tank (with sender)



Specifications

Length:	4.50m
Length (boat/motor/trailer):	6.20m
Height on trailer:	2.00m
Beam:	1.99m
Depth:	0.92m
Weight:	
Open	300kg
Side Console	315kg
Centre Console	320kg
Frontrunner	340kg
Shaft length:	20 inches
HP rating:	60 HP; 50HP Open
Capacity:	4 people (300kg)

Frontrunner



Side Console



Open Boat



White

Yellow

Apple Green

Teal

Cobolt Blue

Regal Blue

Torris Blue

Barrier Red

Available Colours

4.80 Brumby

The brilliant new all-rounder from Polycraft. From family boating to hardcore fishing, the 4.80 Brumby has it covered.

New Release



The 4.80 Brumby, available in Frontrunner, Cuddy Cabin, Centre Console, Rear Centre Console and Side Console models, is the brilliant new all-rounder from Polycraft.

All models feature the unique Polycraft soft, quiet ride, legendary durability, together with exciting new curved styling.

The 4.80 Brumby is fitted with stylish new rounded consoles, that include locations for sounders, gauges and other electronics.

The 4.80 Brumby comes with a spacious front and rear lounge that can be fitted out with comfortable optional upholstery. Additional storage is available in the front lounge, in the stern and under the swivel seats.

Other great new features of the 4.80 Brumby include full pod transom, straight internal walls and wide gunwales.

Available in eight great classic Polycraft colours.

Standard Features

- Anchor well
- Bait box (x2)
- Bilge pumps (x2)
- Bow and hand rails
- Bow roller
- Non-feedback steering
- Pinstripes & Polycraft logo
- Rear fold down lounge
- Rod holders (x4)
- Transom plate with splash well
- Winch point
- 70 litre underfloor fuel tank (with sender)

Frontrunner (only)

- Front lounge
- Console and screen (x2)
- Pedestal box and seat (x2)

Centre Console (only)

- Centre Console box
- Screen and handrail

Side Console (only)

- Side console and screen
- Drivers pedestal box and seat

Optional Features

- Front casting deck insert
- Front lounge cushion pack
- Rear lounge back rest and cushion
- Side pockets
- Ski hooks
- Survey standard foaming



Centre Console



Rear Centre Console



Side Console

Specifications

Length:	4.80m
Length (boat/motor/trailer):	6.60m
Height on trailer:	2.50m
Beam:	2.15m
Depth:	1.01m
Weight:	
Centre Console	540kg
Rear Centre Console	540kg
Side Console	540kg
Frontrunner	560kg
Cuddy Cabin	590kg
Shaft length:	20 inches
HP rating:	60-80HP
Capacity:	5 people (375kg)

White

Yellow

Apple Green

Teal

Cobalt Blue

Regal Blue

Torris Blue

Barrier Red

Available Colours

5.30 Warrior

The 5.30 Warrior is a stylish, well laid-out boat that turns heads both on and off the water.



With the 5.30 Warrior available in Centre Console, Frontrunner and Cuddy Cabin, there is a model to suit nearly every boating application.

For those who enjoy lazy days out on the water just relaxing with friends and family, or if skiing and wake boarding is more your style, then you will appreciate the 5.30 Frontrunner. This model features comfortable seating for all the family, with front and rear lounges and two wraparound helm seats. Access to the bow is easy via the walk-through windscreen.

If you want a boat that gives you the ability to fish the big rivers and impoundments, or to venture offshore for blue water pelagics, then the 5.30 Warrior Centre Console is the boat for you. With a generous front casting deck, underfloor storage and a 2.40m beam, this is a boat with an enormous amount of useable fishing space.

The 5.30 Warrior Cuddy Cabin provides the best of both worlds as a versatile fishing/family boat. Fish offshore for the big ones one day, and then pack a picnic lunch and get away to your favourite spot the next.

Standard Features

- Anchor well
- Bait board
- Bait box
- Bilge pumps (x2)
- Bow, hand and boarding rails
- Bow roller
- Carpeted floor
- Fold down rear lounge
- Front hatch storage
- Non-feedback steering
- Pinstripes and Polycraft logo
- Rod holders (x4)
- Transom plate
- Winch point
- 130 litre underfloor fuel tank (with sender)

Frontrunner (only)

- Console and screen (x2)
- Pedestal box and seat (x2)

Cuddy Cabin (only)

- Cuddy Cabin
- Pedestal box and seat (x2)
- Windscreen

Centre Console (only)

- Centre console box
- Driver storage seat and back rest
- Screen and handrail

Optional Features

- Boarding ladder
- Console seat with back rest (centre console)
- Extra rear bait box
- Four piece cushion pack (Cuddy Cabin/Frontrunner)
- Glove Box (Centre Console/Frontrunner)
- Hydraulic steering
- Rear lounge back rest and cushion
- Ski hooks (pair)
- Survey standard foaming

Specifications

Length:	5.30m
Length (boat/motor/trailer):	7.10m
Height on trailer:	2.40m
Beam:	2.40m
Depth:	1.20m
Weight:	
Centre Console	680kg
Frontrunner	760kg
Cuddy Cabin	830kg
Shaft length:	20 inches
HP rating:	115HP
Capacity:	6 people (450kg)

White

Available
Colour

Frontrunner



Cuddy Cabin



Centre Console



5.99 Frontier

The Polycraft 5.99 Frontier delivers performance, safety and comfort in a boat that performs brilliantly on the water and provides exceptional value for money.



The flagship of the Polycraft range, the 5.99 Frontier has been designed to enhance your entire on water boating experience.

The deep V-hull with distinctive reverse chines delivers a soft, quiet ride with unmatched stability at rest.

The 5.99 Frontier Cuddy Cabin is well equipped with a rear fold down lounge, deluxe bucket seats, carpeted floors and a full wraparound windscreen, to provide protection from the elements for occupants as well as dash mounted electronics.

The dedicated offshore fisherman will appreciate the unique features of the 5.99 Frontier Centre Console model. Features, to name just a few, include a wide body console for protection from the elements and a driver storage seat with padded back rest.

Both fisherman and recreational boaters alike will appreciate the huge amount of internal space in this boat, thanks to its massive 2.50 metre beam.

The exceptional Polycraft 5.99 Frontier, a boat that delivers big on performance, safety, stability and comfort. Don't just take our word for it though, take one for a test ride at your local dealer soon.

Specifications

Length:	6.10m
Length (boat/motor/trailer):	8.20m
Height on trailer:	2.50m
Beam:	2.50m
Depth:	1.40m
Weight:	
Centre Console	940kg
Cuddy Cabin	1040kg
Shaft length:	25 inches
HP rating:	115HP to 175HP
Capacity:	8 people (600kg)

Standard Features

- Bait box (x2)
- Bilge pumps (x2)
- Bollard and bow roller
- Bow, boarding and passenger grab rails
- Carpeted floor
- Front and rear storage bins
- Glove box
- Non-feedback steering
- Pinstripes and Polycraft logo
- Rear fold down lounge
- Rod holders (x6)
- 200 litre underfloor fuel tank (with sender)

Cuddy Cabin (only)

- Cuddy Cabin
- Pedestal box and seat (x2)
- Windscreen

Centre Console (only)

- Wide body Centre Console
- Screen and handrail
- Driver storage seat and back rest

Optional Features

- Bait board
- Boarding ladder
- Front three piece cushion set (Cuddy Cabin)
- Hydraulic steering
- Ski hooks (pair)
- Survey standard foaming

Cuddy Cabin



Centre Console



White

Available
Colour

Accessories

To make your boating experience more enjoyable, Polycraft offers a selection of factory fitted optional extras to allow customisation of your boat.

Be it creature comforts like padded upholstery, boarding ladders or a casting deck insert for the hard core fisherman, optional accessories can be added to give your Polycraft that special custom built look and feel.



Quicksilver Grey/Blue Steel



Quicksilver Grey/Gunmetal



Embossed logo on back of seat



Carpeted floor and front and rear lids

* Models 4.10, 4.50

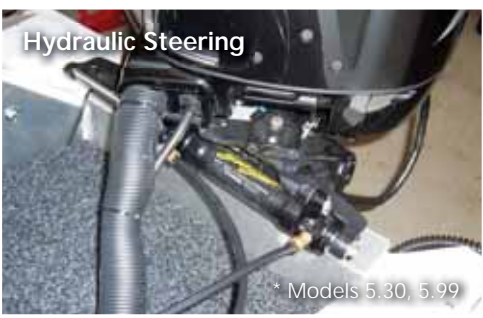

Hydraulic Steering

* Models 5.30, 5.99



Side pockets

* Models 4.10 to 5.99



Rear casting deck insert

* Model 4.10



Rear Storage Box

* Models 4.10, 4.50



70 litre underfloor fuel tank with sender

* Model 4.50



Extra swivel seat and pedestal

* Models 4.10, 4.50, 4.80



Front lounge and casting deck insert

* Model 4.80



Boarding ladder

* Model 4.50



Glove box

* Models 4.50 to 5.99



Ski hooks

* Models 4.50 to 5.99

RM Trailer

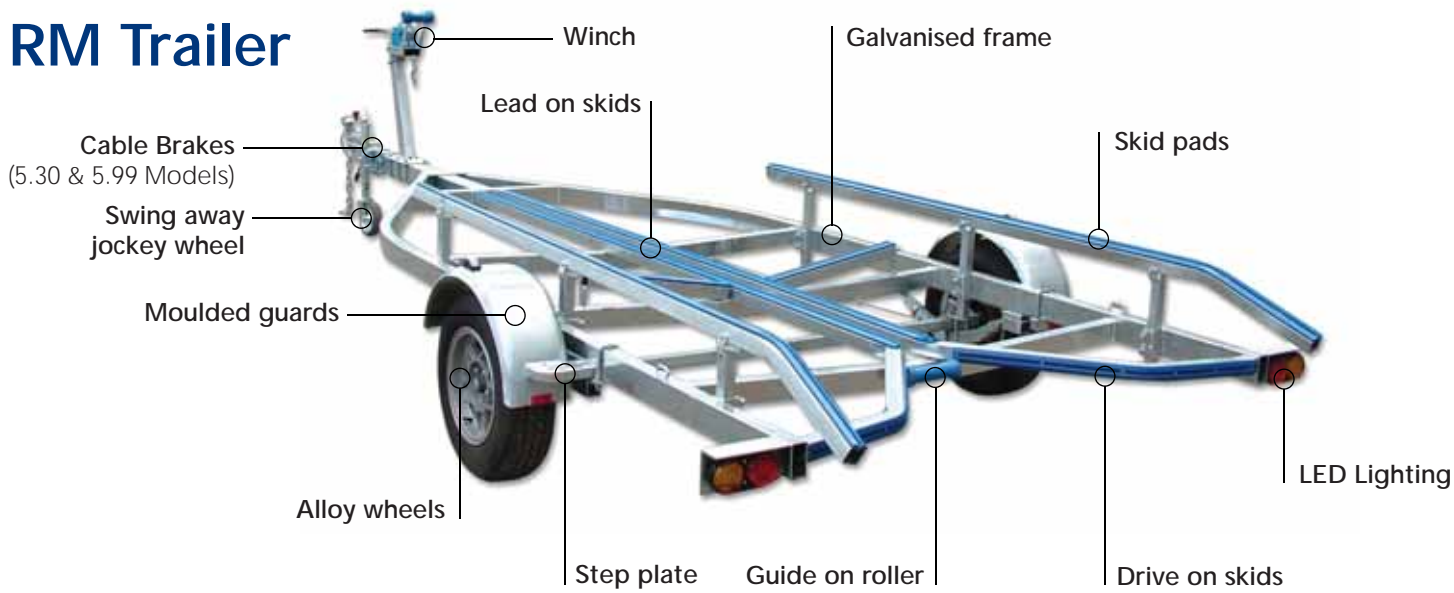

Polycraft uses and recommends RM Trailers, because every trailer in the range has been custom designed to support your Polycraft boat on skids when it is being towed and when it is being stored.

RM Trailers are drive on, and the drive on skids at the rear of the trailer guide the boat into the centre of the trailer for trouble free launching and retrieval.

All 4.10m and over RM Trailers feature fully galvanised frames, swing away jockey wheels, alloy rims, LED lights and light guards.

Special Warranty Note: All Polycraft boats must be trailered on Polycraft approved and recommended trailers. Currently there are two Polycraft approved and recommended trailer manufacturers – RM Trailers and Oceanic Trailers.

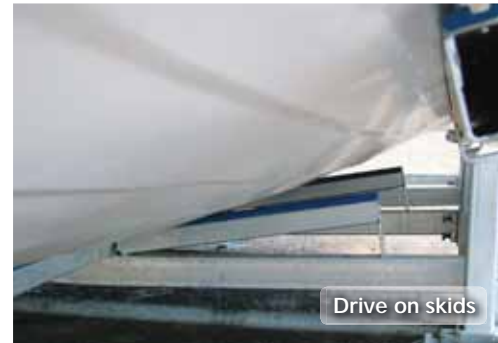

Easy launch and retrieval



How Tough are Polycraft Boats?

Mick's Case – 110km highway crash!

Mick was towing his boat back home after a fishing trip to Hinchinbrook in late 2007. Doing 110km/hour on the Bruce Highway, he heard an almighty crashing sound and saw his 4.55 boat skidding along the bitumen, then catapulting into a cane drain.

What should have been a life ending experience for any boat, ended up being a few hardly noticeable small surface abrasions. Mick said he was amazed at how tough the Polycraft boats were when pushed past any normal boat limits. He was equally impressed with how quick the Polycraft was to fix, to the point where the hull looked as good as new.



The repair job was easy as...



Mark's Case – squashed by a 124ft superyacht!



Mark Schmack, the Operations Manager for Orakei Marina in New Zealand picks up the story –

“We'd just launched the new Ermis 2 (a 38m (124ft) superyacht capable of doing 60 knots) when there were a few problems with the berthing and the Polycraft tender ended up side on to Ermis 2 and between the dock. The driver jumped out just in time to see both port and starboard sides of the Polycraft bend up and smash the centre console windscreen and then also hit the motor cover. You can see on the motor where it hit.”

This is the picture of the Polycraft after the accident and apart from a buckled bowrail, overall it's not looking too bad.”

Do you have an interesting story to share? Send your photos and story to info@polycraft.com.au



Big Barra Hire Boats - Lake Monduran, Queensland

"Polycraft was the only choice for my boat business - hardwearing, no maintenance and easy to put into survey with the survey standard foaming option." - Rob Howell, Owner/Operator of Big Barra Hire Boats, Gin Gin, QLD www.lakem.com.au

The Australian Volunteer Coast Guard Association

"Because of the unique requirements of the South Australian Gulf channels and waterways we urgently needed a shallow water craft in our flotilla. We chose Polycraft, and this vessel will be a huge benefit for our Coast resources." - Janet McDonald, Commander, SAF8 Coast Guard, Port Augusta, SA

John Golback's Polycraft 5.30 Warrior Frontrunner

"I tested a lot of boats before buying a Polycraft. I found it to be the quietest, softest and most comfortable ride of any boat I tried. My wife and daughter both love the boat and we always feel safe due to the inbuilt foam floatation, air pockets trapped between the dual skin and the stable ride." - John Golback, Batehaven, NSW

Brenton Kelley's Polycraft 4.55 Centre Console

"In the 12 months I've had my Polycraft, I've received dozens of positive comments from fellow boating enthusiasts about the strength and quality of my boat. She acts like a much larger boat and not once have I or any of my passengers felt unsafe, even in turbulent seas." - Brenton Kelley (AKA "Powderfish"), VIC



Bryan Griffith's 5.30 Warrior Frontrunner

"When I first saw this boat I knew that it would be the perfect fishing machine. I normally fish with 3 mates, who all average around 100kgs each. We can all lean over and fish on one side of the boat without upsetting the balance. I can't recommend these boats highly enough." - Bryan Griffith, Brisbane, QLD

Clive Howe's 5.99 Frontier Cuddy Cabin

"Heading out to the 50 mile grounds in 20-25 knots, I'm still heading out and fishing when even bigger glass and aluminium boats are getting half way out, then turning around and heading for home. The best boat I've ever owned." - Clive Howe, Bunbury, WA

Fraser Guided Fishing Tours - Mark Bargenquast's 4.10 Side Console

"As a fishing guide I was after the quietest hull I could find and the Polycraft is quieter than any fibreglass boat I have ever experienced, let alone any tinny! The ride is awesome, they are super stable and I can now creep within metres of feeding fish in shallow water. My clients catch rate has risen dramatically." www.fraserguidedfishing.com.au

"I have had several V bottomed tinnies in the past and I must say that the Polycraft 4.10 Challenger leaves them all for dead. The stability at rest is amazing, but what makes this boat unique is its soft ride combined with straight tracking in choppy water. The price for what you get is unmatched by any other boat brand." - Phillip Brown, Padstow, NSW

"I've had my 4.55 Centre Console for nearly 12 months now, and I know it's been said before, but the soft quiet ride really does have to be experienced to be believed. I would never buy another tinny again that's for sure. These boats are light years ahead of aluminium in every way, and never need painting to boot!" - Chris Mani, Charlestown, NSW

To learn more about Polycraft boats visit our web site where you can download the latest brochures, boat reviews, on water video footage and also find contact details for your closest Polycraft dealer.

www.polycraft.com.au

Freecall: 1800 336 603

- Soft, quiet ride
- Strong and durable
- Awesome on water performance
- Easy to clean and maintain



DISCLAIMER

This brochure is designed to provide readers with an introduction to Polycraft's products (including available optional extras). Because of changes in conditions and circumstances, Polycraft reserves the right at any time, and without notice, to discontinue or change the features, designs, materials, colours, specifications and prices of its products, and to either permanently or temporarily withdraw any such products from the market without incurring any liability to any prospective purchaser. Details referred to in this brochure are based on pre-production specifications and could be altered or deleted prior to the boats sale date. Because of variations which occur in manufactured products, all capacities, measurements, dimensions and weights quoted should be taken as approximate only and are subject to change. Polycraft reserves the right to discontinue or change any of the boat hull colours and interior trims referred to in this brochure at any time and without notice. Every effort has been made to depict boat colours and trims as realistically as possible in this brochure, however some variations may occur due to printing limitations.



In need of a Water Tank?

For an extensive range of water tanks solutions, visit:

www.nationalpolyindustries.com.au

